
**INSTALLATION INSTRUCTIONS FOR DETEX ADVANTEX® RIM 10/40 SERIES, F10/40 SERIES,
"H" MODELS (HURRICANE) & "W" MODELS (WEATHERIZED)**

Drawing: 101379: (Stainless Steel)
104600: (Aluminum)

U.S. PATENT NUMBERS:

6009732

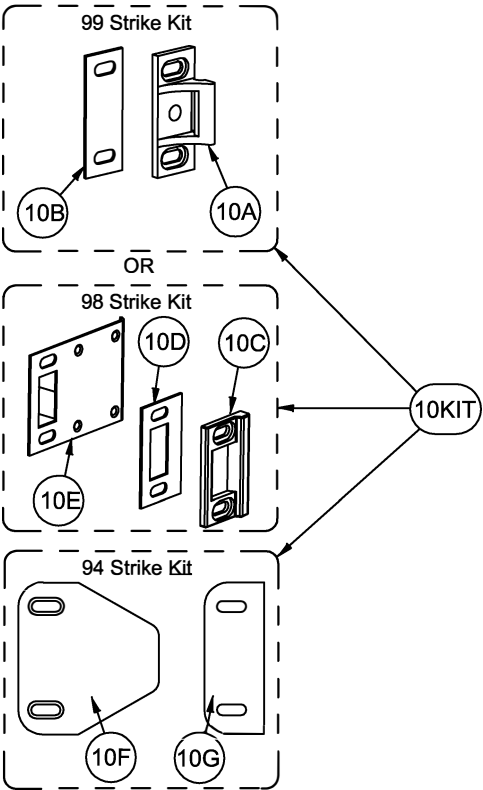
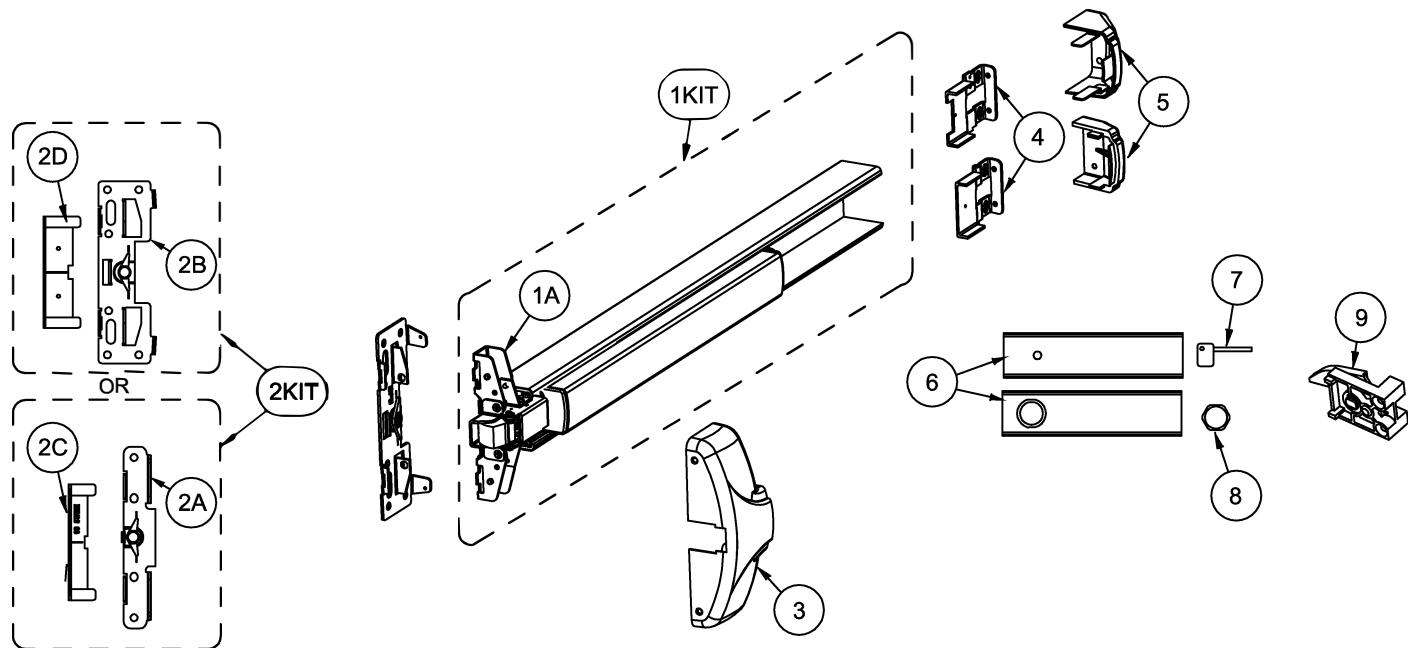
6205825B1

6532777B2

INTERNATIONAL PATENT NUMBER:


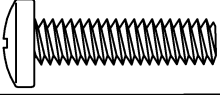






PCT6009732

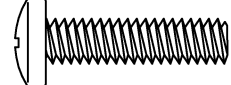
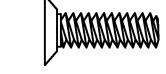

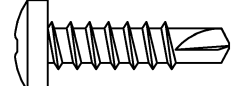


Table of Contents	Page
Device parts breakdown view.....	2
Device parts breakdown list with part numbers.....	3
Hardware List with part numbers & tools required.....	4
Door condition check.....	5
Mounting plate and strike installation.....	6
Device installation.....	7
Cut down procedure, Mortise Cylinder installation.....	8
98 Strike, Strike Hook & Narrow Stile Fascia installation.....	9
94 Double Door Strike installation.....	10
Optional Accessories.....	11



PARTS BREAKDOWN		
Item	Order Part #	Description
1KIT	105500-63	Centercase/Pushpad SubAssembly, 40 series, 36", 630 (includes 1A)
	105500-62	Centercase/Pushpad SubAssembly, 10 series, 36", 630 (includes 1A)
1A	100698-1	Centercase Assembly, Narrow Stile, 40 series
	100698-2	Centercase Assembly, Wide Stile, 10 series
2KIT	103806-1	Mounting Plate/Strike Locator Kit, Narrow Stile (includes 2A & 2C)
	103806-2	Mounting Plate/Strike Locator Kit, Wide Stile (includes 2B & 2D)
2A	100696-1	Mounting Plate, BP2, Narrow Stile
2B	100697-1	Mounting Plate, BP1, Wide Stile
2C	101899	Strike Locator 2" Glass Door (98)
2D	100212	Strike Locator, Standard (99)
3	100311-9	Centercase Cover, Stainless Steel, Narrow, 40 series, 630
	100196-9	Centercase Cover, Stainless Steel, Wide, 10 series, 630
	104602-1	Centercase Cover, Aluminum, Narrow, 40 series, 628
	104640-1	Centercase Cover, Aluminum, Wide, 10 series, 628
4	100147	Endcap bracket for EC1 (ramped) endcap w/o battery holder
	101093	Endcap bracket for EC1 (ramped) endcap w/ battery holder
	104303	Endcap bracket for EC2 (flush) endcap w/o battery holder
	104636	Endcap bracket for EC2 (flush) endcap w/ battery holder
5	101642-9	Endcap, EC1 (ramped) Stainless Steel, 630
	104304-9	Endcap, EC2 (flush) Stainless Steel, 630
	104612-1	Endcap, EC2 (flush) Aluminum, 628
6	100860-54	Fillerplate, Subassembly, S&R, Hex Dogging, HD, 10 series, 36", 630
	100860-49	Fillerplate, Subassembly, S&R, Cylinder Dogging, CD, 10 series, 36", 630
	100860-100	Fillerplate, Subassembly, S&R, Hex Dogging, HD, 10 series, 36", 628
	100860-137	Fillerplate, Subassembly, S&R, Hex Dogging, HD, 40 series, 36", 628
7	100450	Hex Key (for Hex Dogging)
8	100783	Cylinder Nut (for Cylinder Dogging)
9	102216-2	Hex Dogging Assembly
	102216	Cylinder Dogging Assembly
10KIT	100855-2	99 Strike Kit (includes 10A & 10B)
	100855-1	98 Strike Kit (includes 10C, 10D & 10E)
	102212-1	94 Double Door Strike Kit (includes 10F & 10G)
10A	100234-1	Strike, Non-roller
10B	100088	Strike Shim
10C	100480	Strike, Mortise
10D	100482	Shim, Mortise Strike
10E	100481	Shield, Strike
10F	102211	Double Door Strike Plate
10G	102214	Shim, 94 strike

Hardware Table for BASIC device mounting.
Additional hardware is provided per the device configuration in kit form and is addressed on the appropriate pages as required
 EC1 (ramped) Device hardware kit: p/n 101438-1 for Hex Dogging (HD)
 EC1 (ramped) Device hardware kit: p/n 101438-2 for Cylinder Dogging (CD)
 EC2 (flush) Device hardware kit: p/n 105723-1 for Hex Dogging (HD)
 EC2 (flush) Device hardware kit: p/n 105723-2 for Cylinder Dogging (CD)

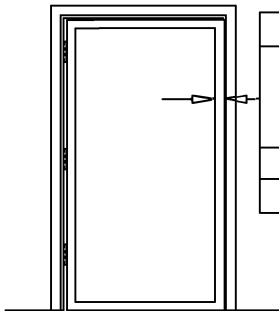
	Fastener Part No	Drill Bit 
	P/N: 100980 1/4-20 x 1" PPH	#7 or 13/64"
	P/N: 101621-5 1/4-20 x 1/4" PPHMS	#7 or 13/64"
	P/N: 101632-2 10-32 x 5/16" PFHUMS (multiple finishes included)	-----
	P/N: 100162-106 6-32 x 3/8" PFHUMS (multiple finishes included)	-----
	P/N: 103276-63 #14 x 1" PPH self-drilling	1/8 pilot hole recommended for self-drilling screws
	P/N: PP-5183-110 #14 x 1-1/4" PPH wood screw	1/8 pilot hole recommended for wood screws
	P/N: PP-5067-25 #14 Lockwasher	

99 Strike Kit: p/n 100855-2 or 98 Strike Kit: p/n 100855-1			
	P/N: 100980 1/4-20 x 1" PPH	#7 or 13/64"	in both kits
	P/N: 100112 10-24 x 5/8" PFHUMS		in 99 kit only
	P/N: 100162-1 6-32 x 5/8" PFHUMS		in 98 kit only
	P/N: 103276-63 #14 x 1" PPH	1/8 pilot hole recommended for self-drilling screws	in both kits
	P/N: 103277-216 #10 x 1" self-cutting PFHU		in 99 kit only
	P/N: 101451-1 #6 x 1" self-cutting PFHU		in 98 kit only

Tools Required:

- | | | |
|-----------------------|-------------------|--|
| Safety Glasses | Pencil | Phillips & small flat Screw Drivers |
| Power Drill | Hammer | Combination Square |
| Tape Measure | Pliers | Center Punch |
| Level | 1/4-20 Tap | Saw for cutting device if necessary (chopsaw preferred) |
- 104881 Page 4

!!!CHECK BEFORE STARTING!!!

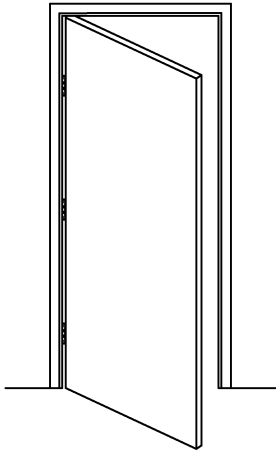
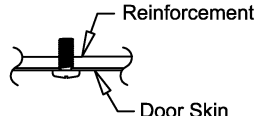


Wide Stile (Surface Strike) 99
Minimum door stile 4-1/2" (114 mm)
Template drawings provide door and frame structural and dimensional specifications for door and frame preparation.
Narrow Stile 98
Minimum door stile 2" (51mm)

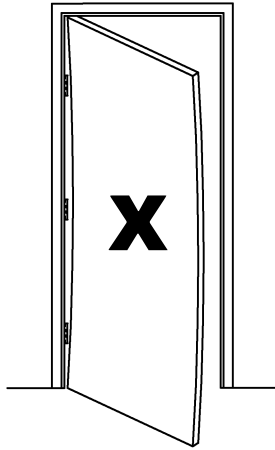
Doors and frames with walls having a structural thickness (metal skin plus reinforcement, or solid wood) to engage less than (3) full screw threads, are considered unreinforced for hardware.

Unreinforced Doors: Use Sex Nuts and Bolts
 Unreinforced Frames: Use Blind Rivet Nuts (see sketch)
 Fasteners for unreinforced openings are not supplied by Detex.

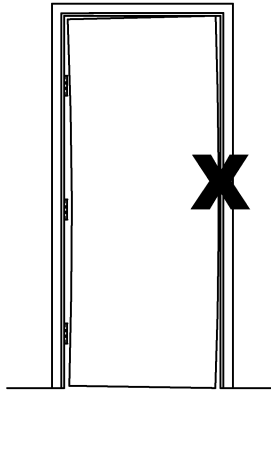
Reinforced door or frame engages at least (3) screw threads.



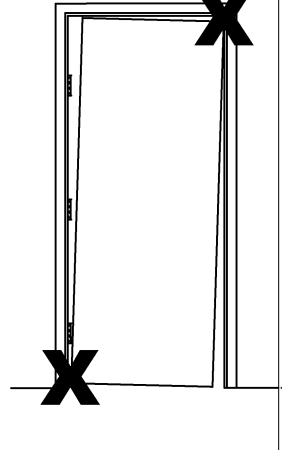
Door Must Swing Freely



Door Must Not be Warped



Door Must Not Bind



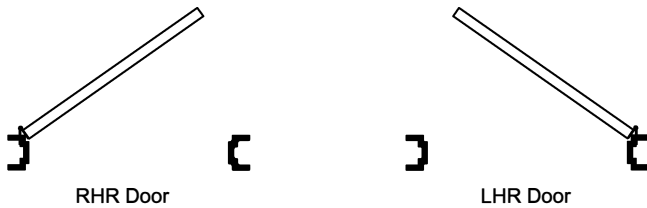
Door Must Not Sag

NOTE: 750mm MAXIMUM DOOR WIDTH OPENING FOR EUROPE FOR 36" DEVICE

1000mm MAXIMUM DOOR WIDTH OPENING FOR EUROPE FOR 48" DEVICE

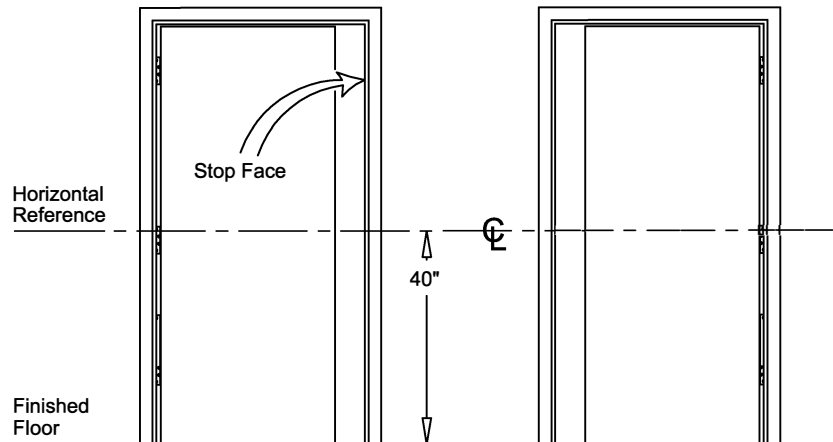
THE SAFETY FEATURES OF THIS PRODUCT ARE ESSENTIAL TO IT'S COMPLIANCE WITH EN 1125.

NO MODIFICATION OF ANY KIND, OTHER THAN THOSE DESCRIBED IN THESE INSTRUCTIONS ARE PERMITTED.



RHR Door

LHR Door

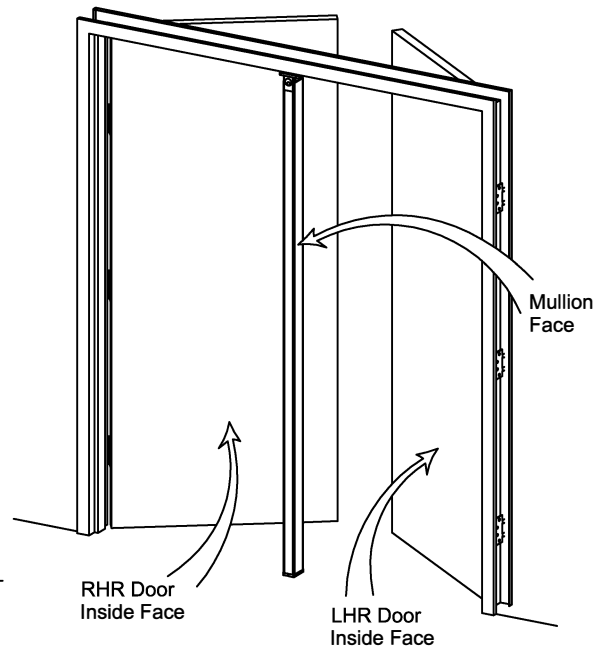


Horizontal Reference

Stop Face

40"

Finished Floor



Mullion Face

RHR Door Inside Face

LHR Door Inside Face

MOUNTING PLATE & STRIKE INSTALLATION:

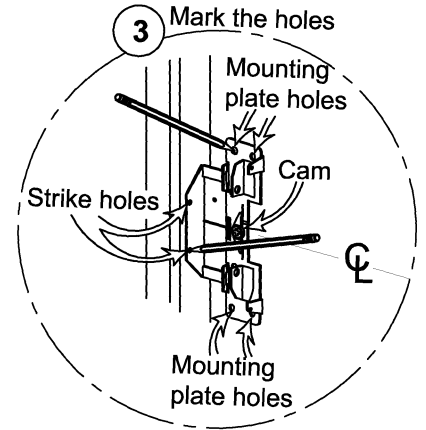
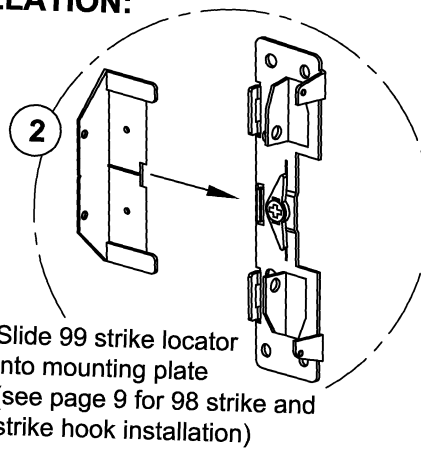
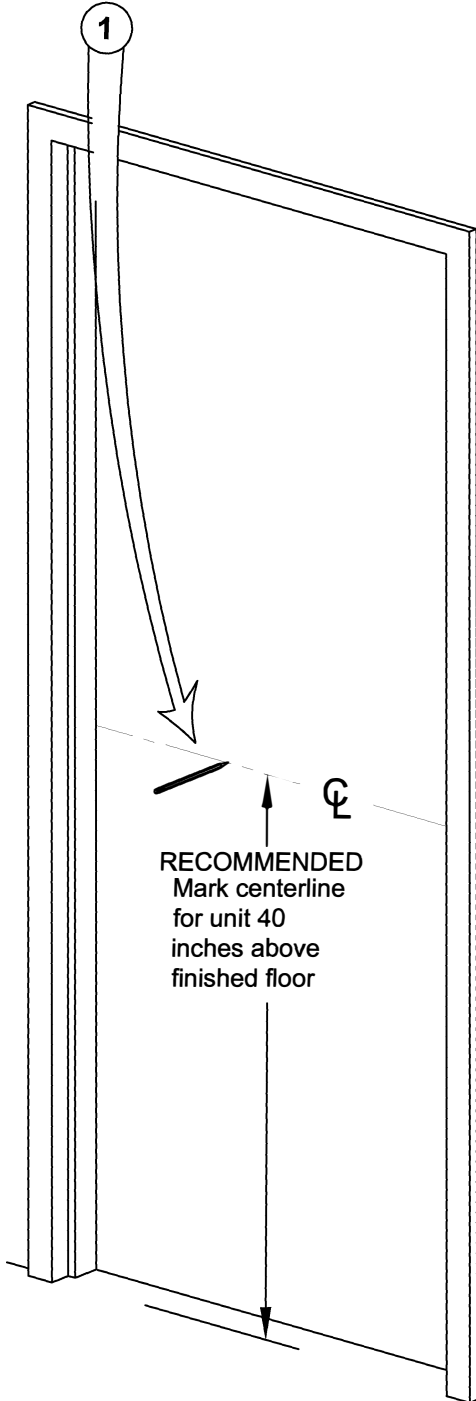
The installation of a 10 or 40 series device is the same except for the mounting plate. (see illustration below)

This instruction depicts a 10 series installation.

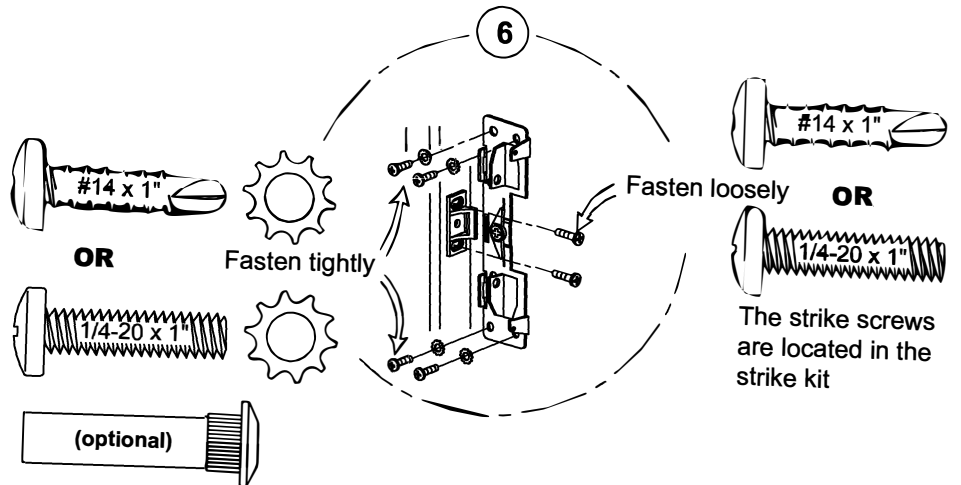
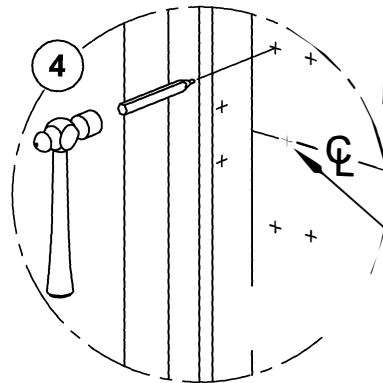
BP1
Mounting plate Subassembly (series 10) (wide stile)
P/N: 100697-1

OR

BP2
Mounting plate Subassembly (series 40) (narrow stile)
P/N: 100696-1



Mounting plate holes:
(4) for wide
(2) for narrow
If outside trim is used mark the hole in center of cam

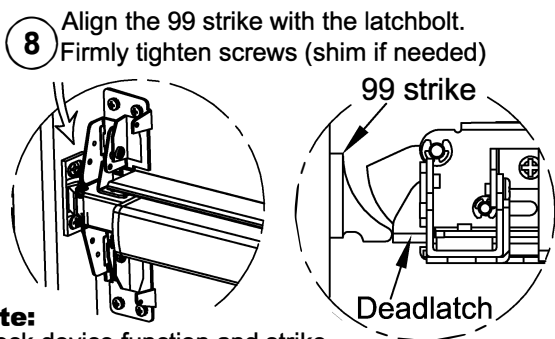
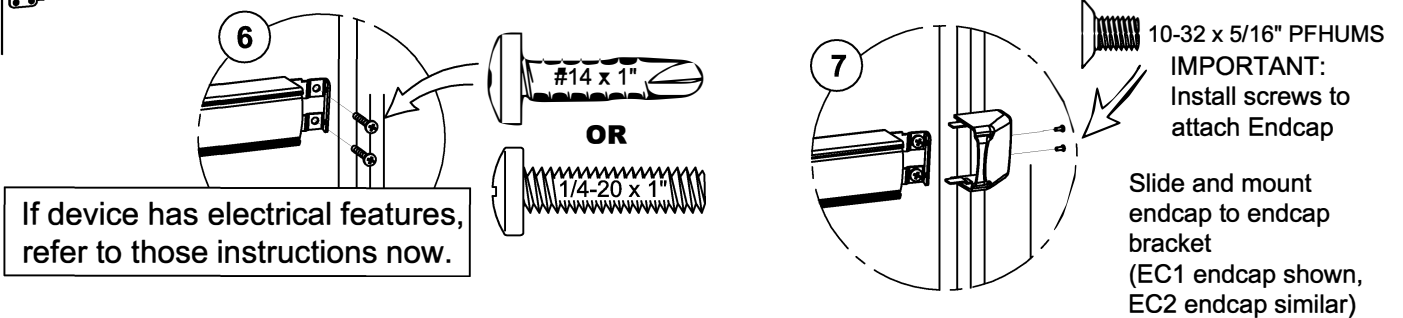
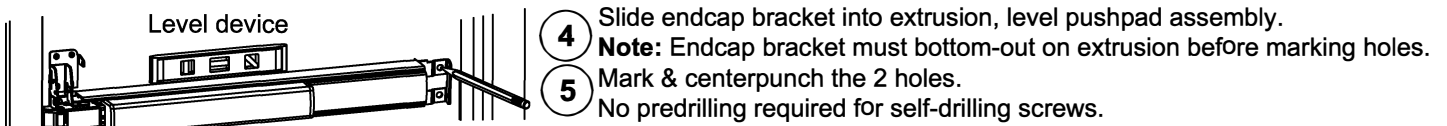
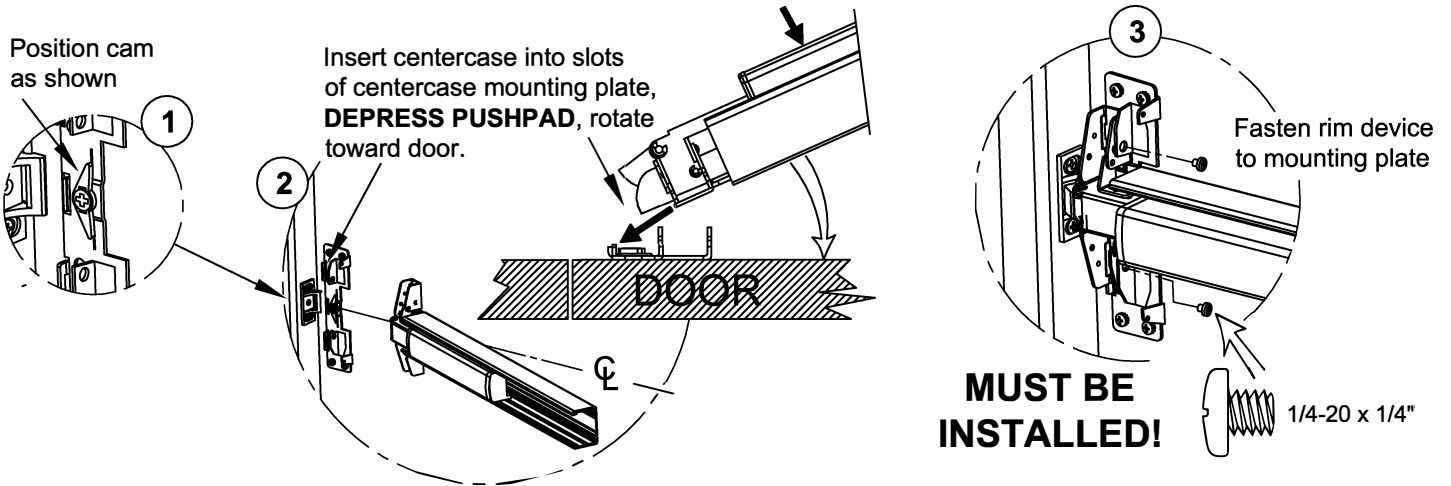


Optional Sex Nuts can be used for thru-bolting the device to the door. Catalog No: SN1 (quantity 2 per order)

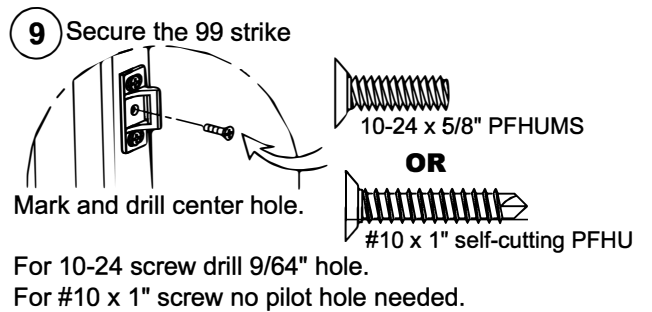
NOTE: HURRICANE rated devices **MUST BE** thru-bolted using either sexnuts or outside mating trim

DEVICE INSTALLATION:

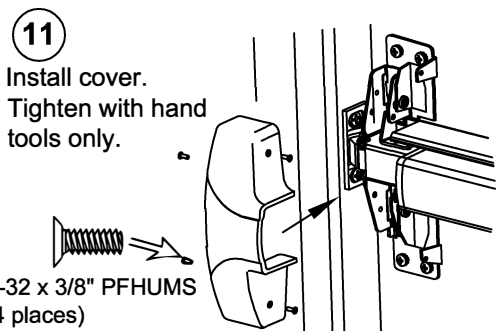
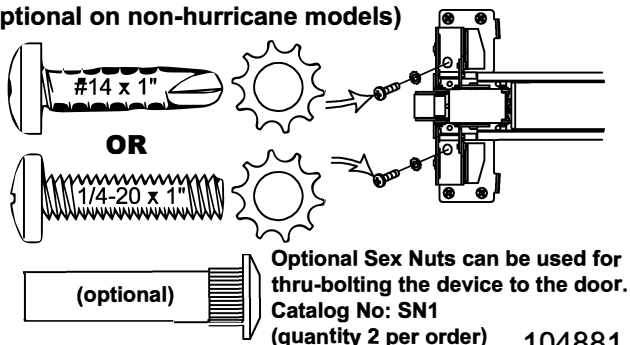
NOTE: If device is too long, refer to next page for cut-down procedure.



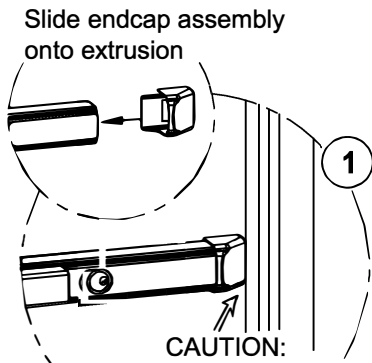
Note: Check device function and strike engagement **BEFORE** going to step 9



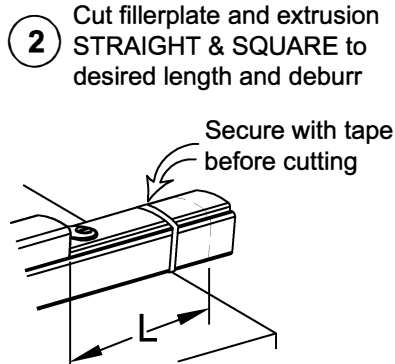
10 REQUIRED SUPPORT SCREWS FOR HURRICANE MODELS
(Optional on non-hurricane models)



CHECKING FOR DEVICE CLEARANCE (Cut-Down procedure if required)



CAUTION:
Check for device and door frame clearance.
If no cut-off needed, continue to mortise cylinder installation.



Non-Electrified Minimum Fillerplate Length	
Type	Length (L)
LD	2-1/2"
HD/CD	3"

For aluminum Advantex finish cutdown applications:

After cutting, the baseplate extrusion can be reversed to place the cut end inside the head cover. To do so, loosen the setscrew inside the aluminum baseplate extrusion and slide extrusion out, reverse, & slide back in. Tighten setscrew.

MORTISE CYLINDER INSTALLATION

CD (Cylinder Dogging) Cylinder Installation

Cylinder nut socket kit
p/n 103779
(sold separately)

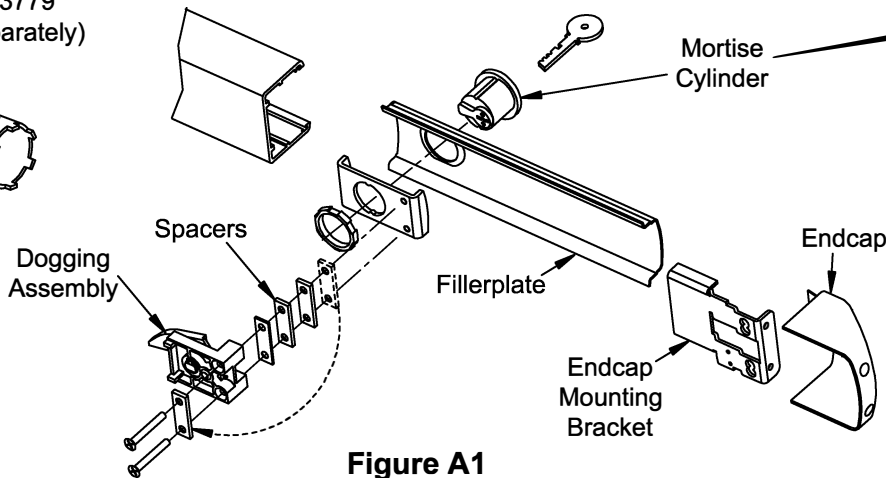


Figure A1

Follow steps "a" through "g" for CD installations

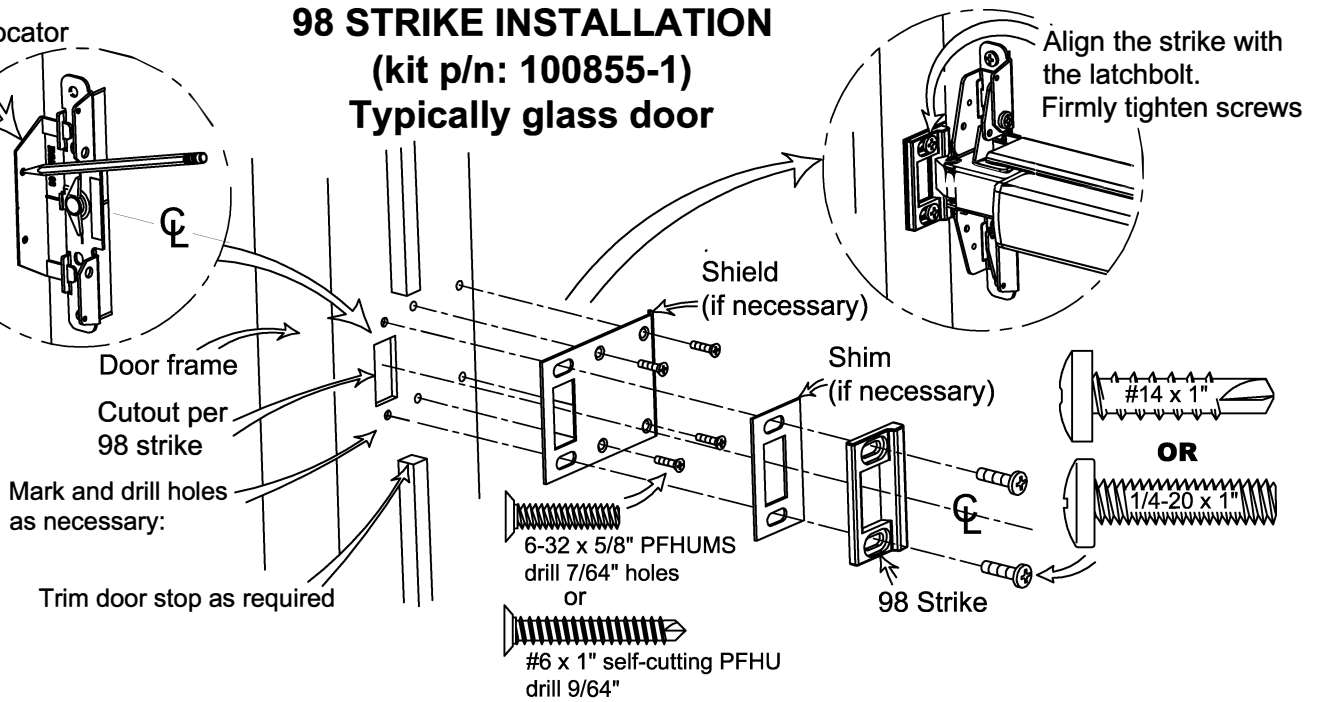
- Remove endcap and endcap mounting bracket.
- Remove fillerplate.
- Remove and discard shipping insert and nut. Loosen (2) screws from dogging assembly.
- Install mortise cylinder (sold separately) with large hex nut provided.
- Trial fit dogging assembly. If cylinder is too short, remove spacers as necessary and reattach them under the (2) screw heads (See Figure A1). Fasten the (2) screws to the rest of the assembly.

NOTE: The key should easily turn in both directions.

- Rotate key counterclockwise
- Assembly complete. Continue with Panic Hardware instruction.

98 Strike locator

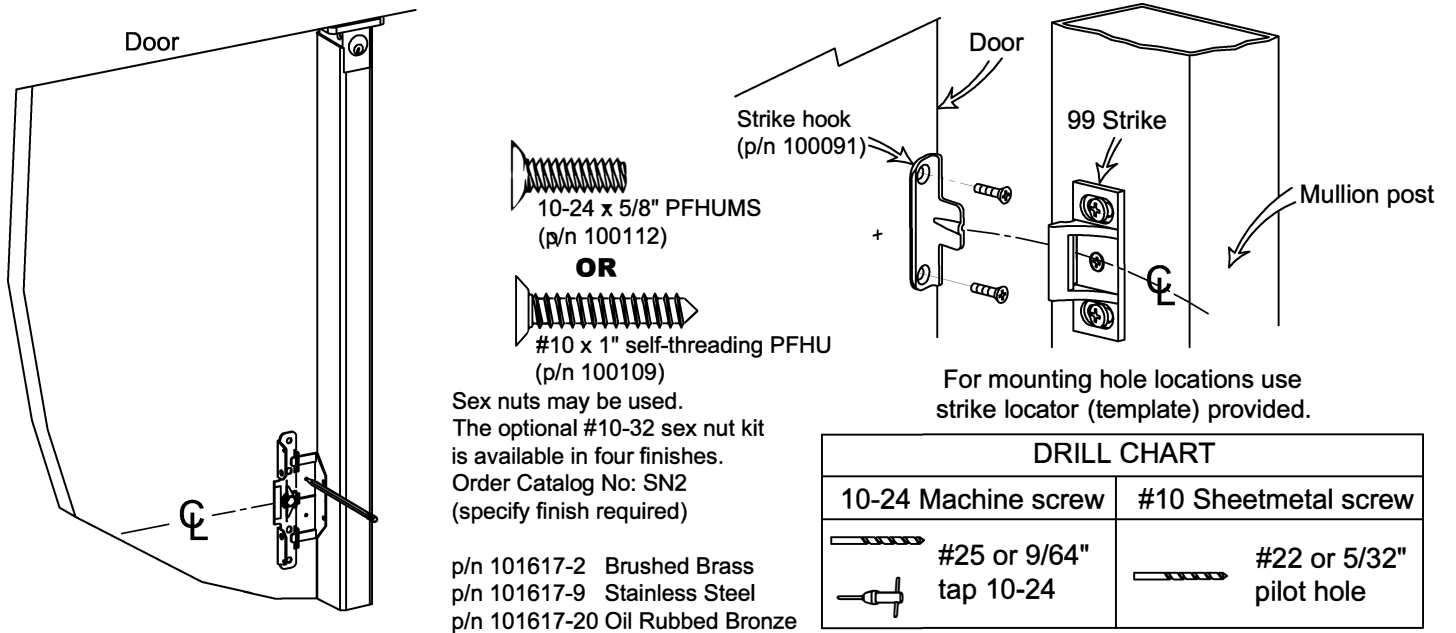
98 STRIKE INSTALLATION (kit p/n: 100855-1) Typically glass door



STRIKE HOOK INSTALLATION

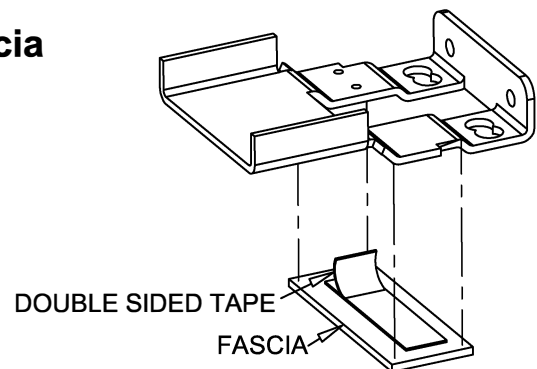
Strike Hook Kit p/n 101795

(Caution: This installation is required on fire rated door openings with removable mullion.)

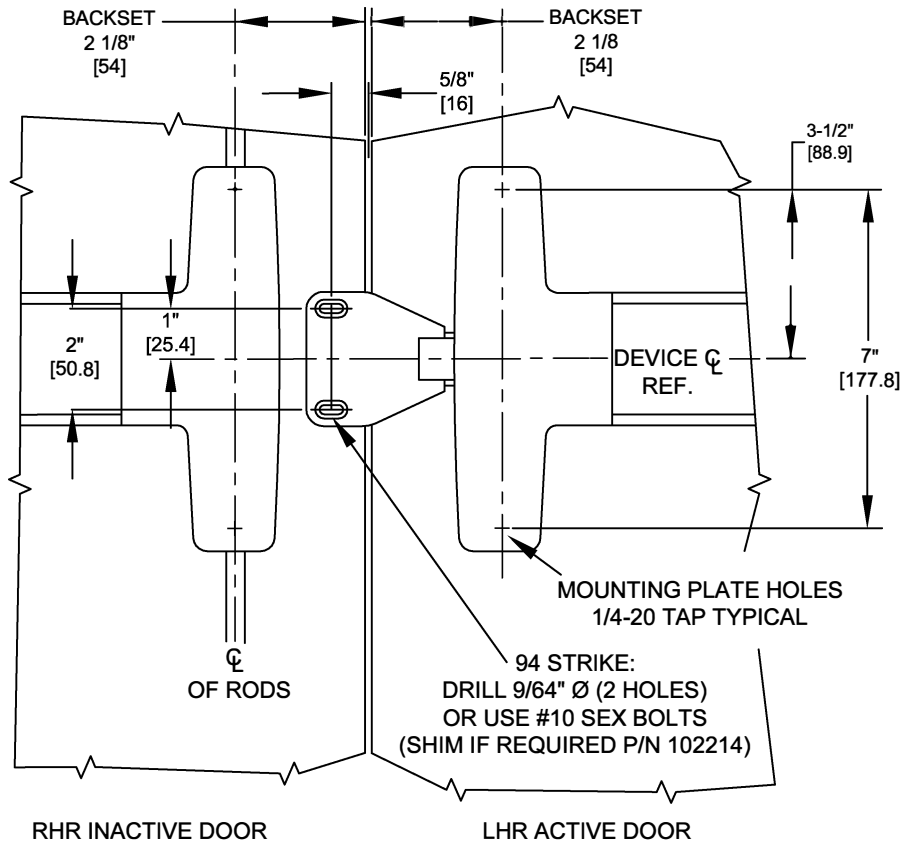


Narrow Stile Endcap Mounting Plate Fascia (For use on Glass Doors) (not used with EC2 endcap)

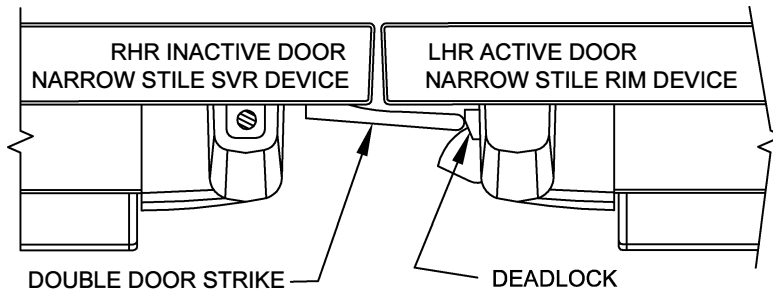
- Remove the endcap mounting bracket.
- Attach the fascia with the adhesive tape.
- Re-attach the endcap mounting bracket.



94 DOUBLE DOOR STRIKE INSTALLATION (if required)



NOTE: FOR DEVICE FUNCTION AND OTHER DIMENSIONS, SEE APPROPRIATE DEVICE AND/OR TRIM INSTRUCTIONS



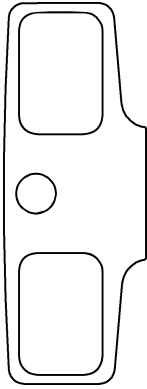
THE DEVICE USED ON THE ACTIVE DOOR SHOULD BE INSTALLED SO THAT THE STRIKE WILL DEPRESS THE DEADLOCK SUFFICIENTLY TO ALLOW FOR ANY AND ALL ALARM / ELECTRONIC FUNCTIONS. ADD SHIM (P/N 102214) AS REQUIRED. TWO PROVIDED IN KIT. THE INACTIVE DOOR SHOULD CLOSE FIRST.

Optional Accessories

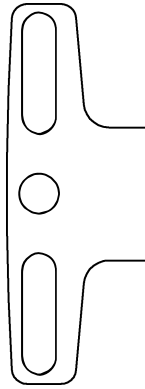
Glass Bead Kit

Catalog No: GB1 - Glass Bead Kit, 10 series
p/n: 101643

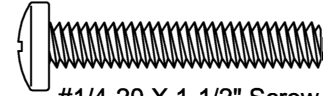
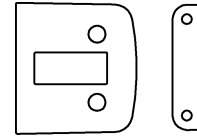
Catalog No: GB2 - Glass Bead Kit, 40 series
p/n: 101644



10 Series (Wide)

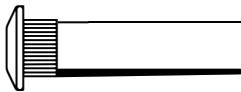


40 Series (Narrow)



#1/4-20 X 1-1/2" Screw
(4) Included

Sex Nut



The #1/4-20 kit is available in (4) finishes:

- Catalog No: SN1 Brushed Brass BHMA 606 Finish
- Catalog No: SN1 Oil Rubbed Bronze BHMA 613 Finish
- Catalog No: SN1 Brushed Chrome BHMA 626 Finish
- Catalog No: SN1 Stainless Steel BHMA 630 Finish

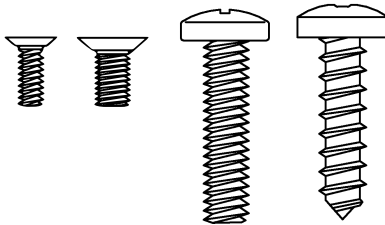
p/n: 101616-X

Tamper Kit

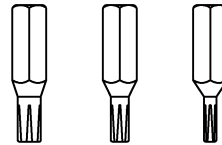
(Security Kit)

Catalog No: SSK3

p/n: 101233



Security Screws



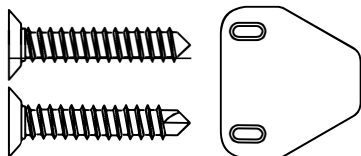
Security Pin TORX® Bits provided

Double Door Strike Kit

Catalog No: 94 (includes shim & screws)

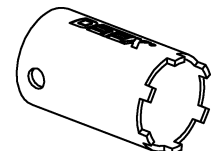
screws

p/n: 102212-1



Cylinder nut socket kit

p/n: 103779



The following Models in the series were evaluated by UL: Controlled Exit Panic Devices; Model 10 and 40. These devices may be suffixed with 01, 02, 03, 08, 09, or 14 followed by C, CN, D, DN, DT, DNT, DU, DNU, P, PN, W or WS, followed by BP1, BP2, BP3, BP5, BP6, BP7 or BP8 followed by 605, 606, 611, 612, 613, 625, 626, 628, 629, 630, 693, 695 or 711 followed by the RHR or LHR, followed by EA, which may be followed by LD or CD, followed by 605, 606, 611, 612, 613, 625, 626, 628, 629, 630, 693, 695 or 711 followed by 98 or 99, followed by 36 or 48.