

# TITAN

POST DRIVERS



## Operator's Manual

### PGPP- Power Puller



## Table of Contents

Introduction .....	3
Safety Warnings .....	4
Assembly Instructions .....	6
Operating Instructions .....	7
Service and Maintenance .....	10
Warranty .....	12
Parts Diagram/List .....	14
Contact Info .....	20

# Safety Warnings

To reduce the risk of serious injury or death, you must understand and follow the safety guidelines, operating instructions, and maintenance guidelines in this operator's manual.

Please read the entire operator's manual before operating the Titan PGPP- Power Puller. Never allow children or people who have not read this manual to operate this machine. Never let your post puller run unattended. When not in use, turn the machine off to prevent unauthorized persons from using it.

**DO NOT** use the Titan PGPP- Power Puller for any purpose other than pulling rods, posts, and stakes from the ground. Misuse may result in serious injury to yourself or others, as well as damage to your puller or surrounding property.

## Personal Protective Equipment (PPE)

Always use approved protective equipment. Operators and all other people in the immediate working area must wear protective equipment as well. Noise emitted from the machine during operation can harm others in close proximity. Please consider this while operating. We recommend the following personal protective equipment:

- Hearing protection with a noise reduction rating (NRR) of 23 dB or greater
- Impact-resistant (ANSI Z87+) eye protection with side guards
- Protective clothing including gloves, boots, pants, etc.

## Pinch Point Warning

To prevent serious injury to your hands or feet, follow the following pinch point guidelines. Never reach into the chain enclosure or adjust the puller jaws while the engine is running. Never place your hands between the post and the front face of the puller during operation. Keep clear of the puller jaws during operation, as they free-fall from the top of the puller and land forcefully at the base of the puller. Keep clear of the base of the puller during operation, as it is driven forcefully into the ground as the puller jaws engage the post.



## Gasoline and Exhaust

Gasoline is highly flammable and explosive. You can be seriously injured when handling and storing gasoline improperly. Always use an approved gas storage container for your fuel. Never attempt to add gasoline to your Titan PGPP- Power Puller while the engine is hot or running, as there is a chance of fumes igniting and causing severe injury or death, as well as damage to your machine.

Never use the Titan PGPP- Power Puller inside a building or unventilated area. The engine exhaust contains poisonous carbon monoxide gas that can build up to dangerous levels in closed areas. These fumes can cause unconsciousness or death.

## Vibration Hazard Warning

Prolonged use of a power tool exposes the operator to vibrations, which may cause white finger disease or carpal tunnel syndrome. These conditions reduce the ability of the hands to feel and regulate normal temperature, produce numbness and burning sensations, and may even cause nerve and circulation damage. If numbness, tingling, pain, clumsiness, weakened grip, whitening of the skin, or any other symptoms occur at any time when operating the machine, or after operating the machine, immediately stop use of the machine and seek medical attention. Continued use of the machine after the occurrence of any such symptom may increase the risk of symptoms becoming more severe and/or permanent.

- Wear gloves for comfort and grip. Keep hands warm while operating.
- Check the machine for loose connectors and components, as these could lead to increased levels of vibration.
- Always keep a firm grip on the handles, but **DO NOT** excessively squeeze the handles.

## Maintenance Warning

If the pinch point warning label on your Titan PGPP- Power Puller falls off or is not able to be read clearly, replace it immediately. Call Titan Post Drivers ((702) 293-4262) for a new warning label at no cost to you.

Regular maintenance is a prerequisite for keeping the machine safe and functioning. With proper use and maintenance, your Titan PGPP- Power Puller will provide you with years of service. Any damage or malfunction caused by unauthorized use, parts, or modifications to the machine will not be covered under warranty or carry any significance for any type of product liability.

- Carefully follow all the maintenance guidelines and operating instructions in this manual.
- Periodically inspect the puller for missing or loose components, as well as damage needing repair
- Replace damaged/worn parts immediately.
- Engine maintenance is to be conducted according to the Honda specifications found in the Honda GX50 manual. The operator needs to take careful note of all warnings and dangers outlined in the engine manual.
- For major service or repairs to the machine, contact your local Titan distributor or your place of purchase.
- For engine service or repairs, contact your local Honda dealer.

# Assembly Instructions

Item numbers in this section can be used to reference the parts diagram and parts list at the end of this manual.

Included with your Titan PGPP- Power Puller is a set of Allen wrenches (3, 5, 6, and 8mm), as well as a pair of snap-ring pliers. In addition to these tools, you will need either two crescent wrenches or two 30mm (1-3/16") wrenches/sockets.

## Install the Handle Assembly

1. With the included set of Allen wrenches, remove the four M8X40 CAP SCREWS (#25) securing the HANDLE BLOCK CLAMPS (#23) to the PROTECTION BRACKET HANDLE (#21).
2. With the throttle "STOP" button facing away from the puller body, fasten the protection bracket handle to the BOTTOM PROTECTION BRACKET (#24) with the four M8x40 cap screws and handle block clamps.

## Install the Base Extension

1. Locate the BASE EXTENSION (#58) within the walls of the cardboard packaging.
2. Fasten the base extension to the BASE (#47) with two M8X15 CAP SCREWS (#59).

## Install the Wheel Assembly

1. Screw the AXLE BRIDGE (#51) into the top set of holes on the main body with three M8X20 CAP SCREWS (#52).

NOTE: The other hole sets can be used when different sized replacements wheels are installed on the puller. This prevents the puller from excessively tilting when stood upright.

2. Remove the two M20 CAP NUTS (#57) from each end of the AXLE (#53).
3. Slide the axle into the axle bridge, then slide one M20 WASHER (#54) onto each end of the axle.
4. With the included snap ring pliers, retain the M20 washers against the axle bridge using two 20MM SNAP RINGS (#55).
5. Install two 20mm snap rings onto the next set of axle grooves, then slide one M20 washer onto each end of the axle.
6. Slide one WHEEL (#56) onto each end of the axle until it reaches the washer and snap ring.
7. Slide one M20 washer onto each end of the axle, then retain the wheel and washer with one 20mm snap ring on each end of the axle.
8. Thread one M20 CAP NUT (#57) onto each end of the axle and tighten securely using two crescent wrenches or two 30mm (1-3/16") wrenches/sockets.

# Operating Instructions

To reduce the risk of serious injury or death, you must understand and follow the safety guidelines, operating instructions, and maintenance guidelines in this operator's manual. Every new person who uses this machine must be educated on and fully understand the information within this operator's manual. Never allow children or people who have not read this manual to operate this machine. In addition, be sure to read and understand the starting instructions for the Honda GX50 engine.

For optimal performance and to prevent potential injury or damage to your machine, please follow these guidelines:

1. **ALWAYS** keep the puller square to the post while pulling. Otherwise, the post can become pinned to the front face of the puller.
2. **ALWAYS** keep the post centered in the puller jaws.
3. **ALWAYS** use the correct size jaw set for the size of post you are pulling.
4. **NEVER** place your hands between a post and the front face of the puller, or inside the chain enclosure, during operation.
5. **KEEP CLEAR** of the puller jaws during operation, as they free-fall from the top of the puller and land forcefully at the base of the puller.
6. **KEEP CLEAR** of the base of the puller during operation, as it is driven forcefully into the ground during operation.
7. Check the oil level of the Honda GX50 engine:
  - **ADD ENGINE OIL WHEN NEW.** Oil is drained from the engine after factory testing. It is recommended that you initially add 1.1 bottles (110 cm<sup>3</sup> or 3.7 fl. oz.), then check the level. Each included bottle of oil contains 3.4 oz of engine oil. **DO NOT use two (2) full bottles of oil to fill the engine initially.**
  - Add oil if required to fill to the bottom edge of the oil fill hole. Use 10W-30 oil. **DO NOT OVERFILL.** Always set the post puller in an upright position to check the oil level. A proper oil level is essential for the proper function of the post puller. Overfilling the oil will result in loss of power and could cause permanent damage to your engine.
8. Visually check inside the chain enclosure for excessive debris or foreign objects, removing, as necessary.
9. Check all fasteners and tighten, as necessary.
10. **DO NOT** use your Titan PGPP- Power Puller if there is any damage or wear to any of the controls or safety devices.

## Resetting Puller Jaws

- If the puller jaws are not resting at the bottom of the puller, you must reset them before interchanging jaw sets or pulling a post.
- To reset the jaws with the engine **OFF**, lift on the pawl clutch housing (#32) using the holes on its face. This will disengage the jaw assembly from the chain, allowing it to fall to the base of the puller.
- To reset the jaws with the engine **ON**, engage the throttle until the jaws reach the top of their travel and self-release, falling to the base of the puller.

## Interchanging Jaw Sets

- Always use the correct size jaw set for the size of post you are pulling. Each jaw set is marked with the size of post it is intended to be used with. To interchange jaw sets:
  1. Loosen the keeper screw (#64) with the provided Allen wrench and rotate the keeper (#61) out of the way.
  2. Slide out the old jaw set and slide in the new jaw set.
  3. Rotate the keeper over the jaw and tighten the keeper screw.

## Refueling

- Always turn the engine off and allow adequate time for it to cool before refueling. **ONLY USE UNLEADED FUEL WITH 86 OCTANE OR HIGHER.**
- **NEVER** refuel your puller with the engine hot, running, or in an unventilated area. Fuel vapors are extremely flammable and can cause severe injury or death if ignited by a spark or excessive heat from a hot engine.
- Fill the tank on level ground and avoid spilling fuel on the motor. Always allow any spilled fuel to evaporate before restarting the engine.
- Ensure the fuel cap is adequately tightened before restarting the engine.

## Safe Starting

- Place the machine on a secure, solid surface. Maintain a safe posture and balance. **DO NOT** start the post puller anywhere except in an open, well-ventilated area. Never use your machine inside an enclosed building.
- When you pull the starter grip, **DO NOT** wrap the starter rope around your hand or wrist. **DO NOT** allow the grip to snap back, but rather guide the starter rope slowly back to permit the rope to rewind properly. **DO NOT** extend the starter rope to its full length. Failure to follow this procedure may result in serious injury to hand or fingers or may damage the starting mechanism.
  1. If the engine is cold, close the choke by moving the choke lever up.
  2. Press the priming bulb until fuel can be seen inside the fuel return line.
  3. Pull on the starter grip to start the engine, and gently return the starter grip to the normal position.

4. As the engine warms up, gradually open the choke by moving the choke lever down.

## Restarting a Hot Engine

- If the engine is operated at a high ambient temperature for a lengthy amount of time and then turned off to sit for a short time to cool off, it may not restart on the first pull. **IF NECESSARY**, use the following procedure. Failure to do so may result in personal injury.
  1. Move the choke lever down to the open position.
  2. Hold the throttle in the max speed position while holding in the on-off auto reset button.
  3. Pull the starter grip 3 to 5 times while holding in the throttle and the auto reset button.
  4. Follow the safe starting procedures listed above and start the engine with the choke in the open position.

## Pulling a Post

- Be sure to follow all guidelines as outlined in the *Safety Warnings* section and perform any required maintenance as outlined in the *Service and Maintenance* section prior to use.
- Before starting the engine, do the following:
  - If the jaws are not resting at the bottom of the puller, reset them as described in the *Resetting Puller Jaws* section.
  - Check the fit of the jaw set and interchange for a different size set if necessary.
  - Align the puller with the post, with the post centered in the notch of the foot plate and the puller jaws.
- Start the engine as outlined in the earlier sections.
- Be sure to keep one hand on the throttle and one hand on the grip during use.
- Keep the post square to the frame of the post puller to prevent the post from binding against the machine. If not aligned properly, you could cause damage to the machine or your post.
- **Slowly** engage the throttle until the jaws engage the post; then, ease on the throttle until the post is pulled loose.
- At the top of the puller's travel, the jaws will release from the post and both the jaws, and the post will fall to the ground. If possible, have someone assist in preventing the post from falling and striking anyone/anything.
- When pulling longer posts, multiple pulls may be required to fully remove the post.
- When finished, press/hold the auto-reset button on the throttle handle until the engine turns off.

## Transporting/Storing

- If transporting in the horizontal position, ensure that the gas cap is tight. Be aware that even with the gas cap tightened, there is a chance that fuel may leak from the engine. If leaking occurs during transportation, drain the engine of fuel before continued transportation.
- Store your Titan PGPP- Power Puller in the upright position to prevent fuel from leaking.



# Service and Maintenance

The Titan Gas-Powered Post Puller has been manufactured and designed to give you years of trouble-free post pulling. Always refer to the Honda GX50 manual for service and maintenance guidelines on your engine. The following maintenance guidelines will keep your machine in top-performing condition.

**If you are experiencing an issue with the Honda engine, please contact your local Honda dealer for parts and service. Titan Post Drivers does not carry the engine parts for Honda, nor does Titan Post Drivers determine the warranty, which is honored by Honda.**

## Before each use:

1. Ensure that the Chain Lock Shaft (#35) and Hex Flange Nut (#50) are tight. **The specified torque is 74 ft-lb.**
  - Verify that the Nord-Lock Washers (#49) are oriented appropriately; the coarse serrations should be facing each other, and the fine serrations should be facing outward.
  - Verify that the stud on the Slot-Lock Washer (#49A) is fully seated within the slot of the Base (#47).
2. Check chain tension. ½" to 1" of chain play is acceptable.
3. Check the engine oil level by holding the machine in an upright position. Laying the machine down to check the oil will give you a false reading. Use SAE 10W-30 oil to top off if necessary.
4. Check the engine air filter. If it is soiled, clean or replace it.
5. Check all post puller fasteners and retighten if necessary. If you choose to reinstall any bolts with new Loctite Blue 243, you must clean the bolt and bolt hole thoroughly to remove any grease residue. The Loctite will not be effective if grease is present. Follow torque requirements for grade 8 hardware.
6. Visually check the inside of the puller body for any debris or foreign objects, removing, as necessary.
7. Check for any fluid leaks.

## First 10 hours use:

1. Change the engine oil following the guidelines in your Honda GX50 manual. Dispose of discarded oil in accordance with all local, state, and federal regulations. **DO NOT OVERFILL.** Always check the oil level by holding the machine in an upright position.
2. Check all engine and post puller fasteners and retighten if necessary. If you choose to replace or reinstall any bolts with new Loctite, follow the guidelines listed above pertaining to Loctite. Follow torque requirements for grade 8 hardware.
3. **LUBRICATE:** Initially lubricate your post puller with Light Chain/Cable Fluid in the following areas:
  - Chain (#26)
  - Bottom hinge plate bolts (#33)
  - Jaw master slots (#38)

### Every 10 hours of use:

1. Lubricate the puller as described in Steps 2 and 3 of the **First 10 Hours Use** guidelines.
  - Note: Under heavy use and/or dirty/dusty conditions, lubricate these areas more frequently.

### Every 3 months or 25 hours of use:

1. Change the engine oil following the guidelines in your Honda GX50 manual. Dispose of discarded oil in accordance with all local, state, and federal regulations. **DO NOT OVERFILL.**
2. Replace air filter. This should be performed more often if your post puller is operated in dusty conditions.
3. Check all engine and post puller fasteners and retighten if necessary. If you choose to replace or reinstall any bolts with new Loctite Blue 243, follow Step 3 of the **Before Each Use** guidelines pertaining to Loctite. Follow torque requirements for grade 8 hardware.

### Cleaning

To clean your post puller, simply spray down the exterior with water.

1. Do not use chemical cleaners to clean your post puller.
2. Do not spray water onto a hot engine. Allow the puller and the engine to cool before cleaning.
3. Do not spray water directly into the chain enclosure or into the main body.

If reassembling your post puller fasteners using Loctite Blue 243, follow Step 5 of the **Before Each Use** guidelines pertaining to Loctite.

If you are experiencing performance issues with your Titan Gas-Powered Post Puller, or have any questions not answered in this manual, please contact your local Titan distributor or your place of purchase for more assistance.

# Parts Diagram

1 of 2

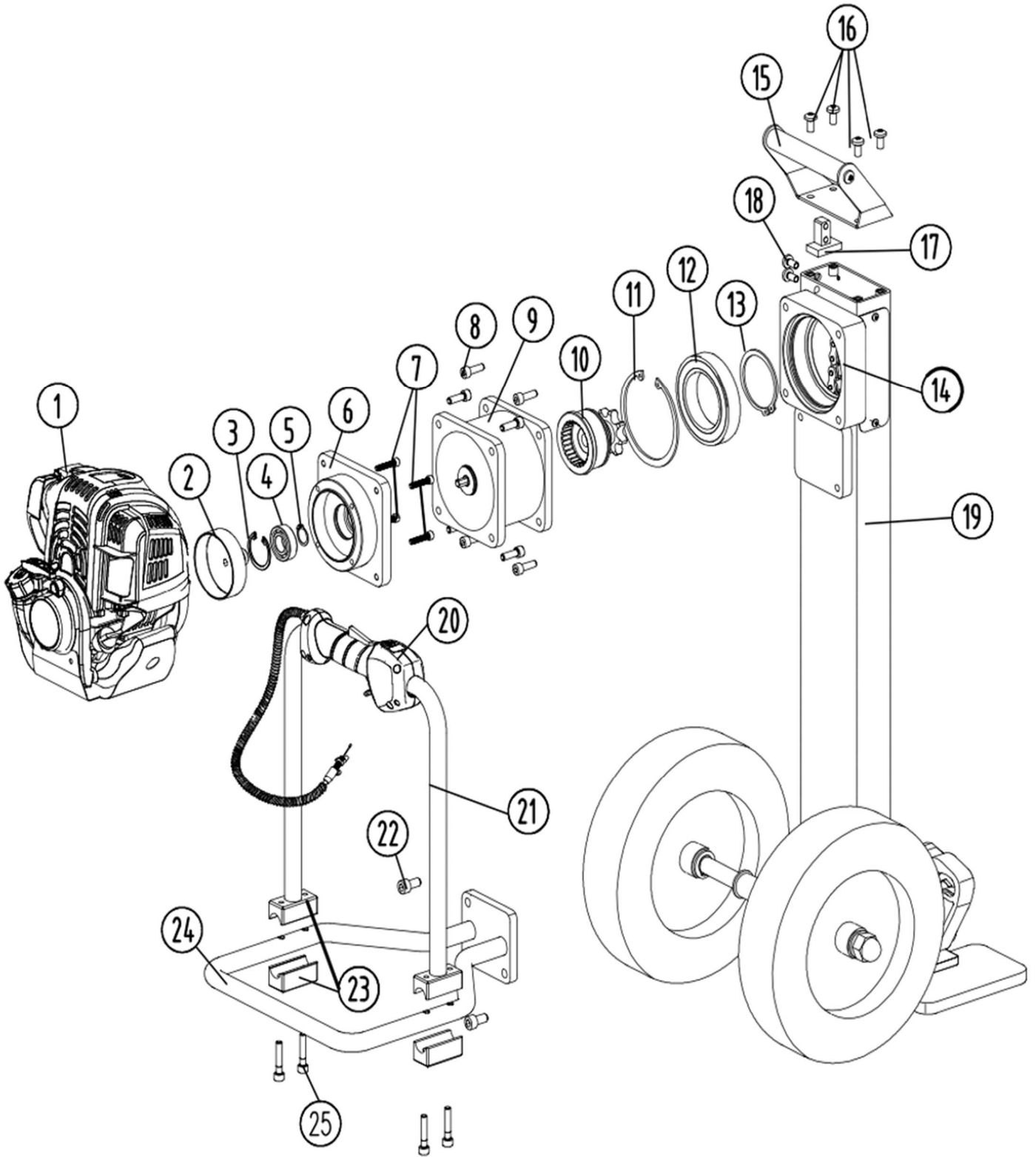

# Parts Diagram

## 2 of 2

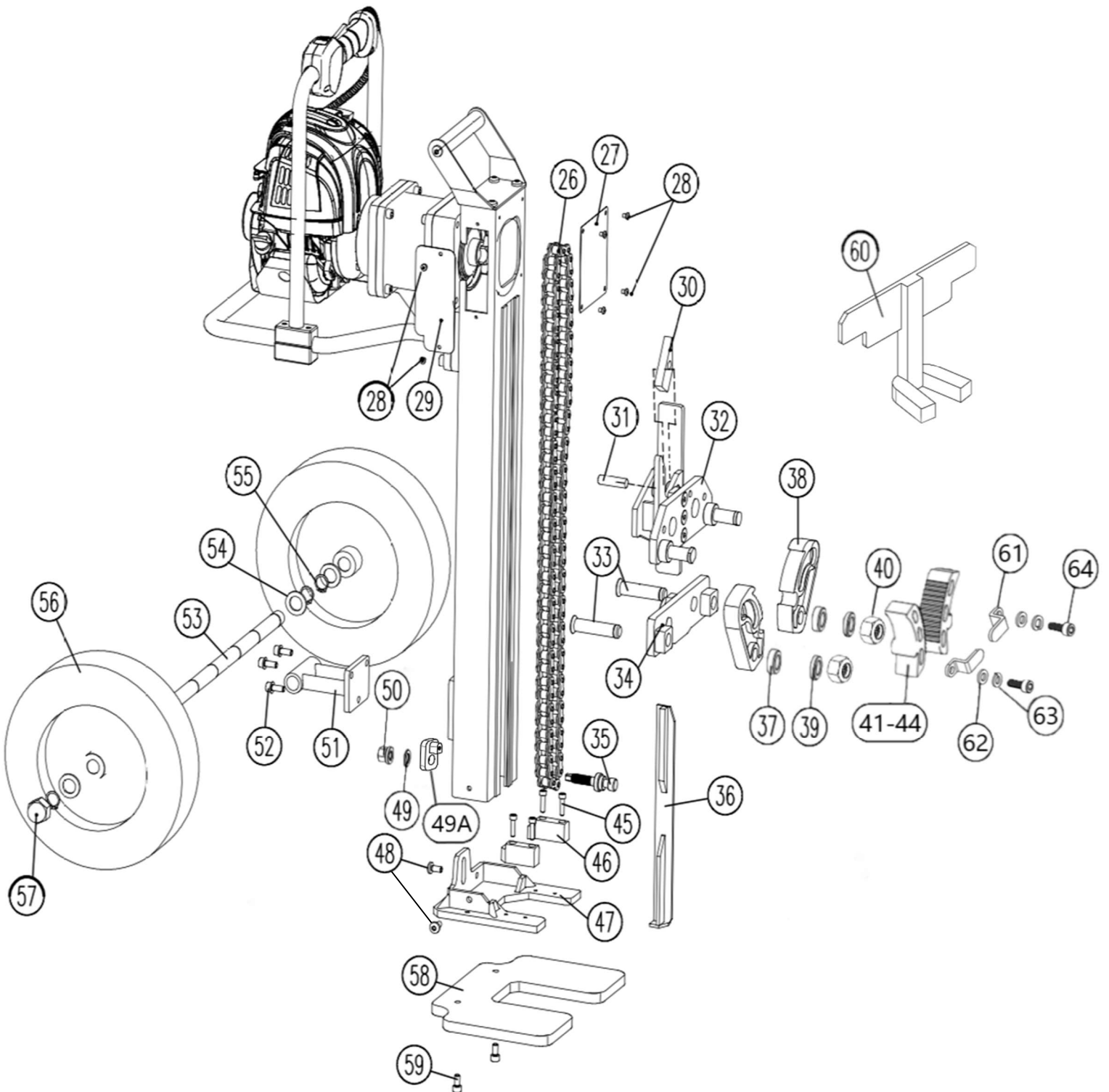

# Parts List

Individual Service Components				
No.	Service Code	Description	Specification	Qty
1	YPGDE50	Honda GX50 Engine	See Honda Dealer for individual service parts	1
9	PGPGB	Gear Box		1
15	PGPTH	Transport Handle		1
17	PGPSB	Stop Block		1
20	YPGD33X	Throttle		1
26	PGPRC	Roller Chain	#60, 3/4" Pitch, 84 Links	1
30	PGPPC	Pawl Clutch		1
34	PGPBHP	Bottom Hinge Plate		1
41	PGPJ325	Post Jaw Set	2.5-3.375"	2
42	PGPJ250	Post Jaw Set	1.75-2.5"	2
43	PGPJ175	Post Jaw Set	1-1.75"	2
44	PGPJ100	Post Jaw Set	0-1"	2
60	PGPJTS	Tent Stake Adapter		1
61	PGPJK	Jaw Keeper		2
65	YPLPDPP	Safety Label	Not Shown	1

Clutch Housing Kit				
No.	Service Code	Description	Specification	Qty
	<b>PGPCHK</b>	<b>PGP Clutch Housing Kit</b>		
2		Clutch Drum		1
3		Internal Snap Ring	For ID 42mm	1
4		Ball Bearing	6004-2RS	1
5		External Snap Ring	For OD 20mm	1
6		Clutch Housing		1
7		Socket Head Cap Screw	M6-1.0x30	4

Handle Assembly Kit				
No.	Service Code	Description	Specification	Qty
	<b>PGPHAK</b>	<b>PGP Handle Assembly Kit</b>		
21		Protection Bracket Handle		1
22		Socket Head Cap Screw	M10-1.5x20	2
23		Handle Block Clamp		2
24		Bottom Protection Bracket		1
25		Socket Head Cap Screw	M8-1.25x40	4

## Parts List, Cont.

Sprocket Assembly Kit				
No.	Service Code	Description	Specification	Qty
	<b>PGPSAK</b>	<b>PGP Sprocket Assembly Kit</b>		
10		Driving Sprocket		1
11		Internal Snap Ring	For ID 110mm	1
12		Ball Bearing	6014-2RS	1
13		External Snap Ring	For OD 70mm	1

Bottom Hinge Plate Hardware Kit				
No.	Service Code	Description	Specification	Qty
	<b>PGPBPHK</b>	<b>PGP Bottom Hinge Plate Hardware Kit</b>		
33		Bottom Hinge Plate Bolts		2
34		Bottom Hinge Plate		1
37		Spacer	Φ33xΦ18.5x10	2
38		Chuck Jaw Master Set	Does Not Include #41-44	1
39		Washer	M18	2
40		Nylon-Insert Lock Nut	M18-1.5	2
61		Jaw Keeper		2
62		Washer	M6	2
63		Split Lock Washer	M6	2
64		Socket Head Cap Screw	M6-1.0x15	2

Wheel and Axle Assembly				
No.	Service Code	Description	Specification	Qty
	<b>PGPWAK</b>	<b>PGP Wheel and Axle Assembly, Kit</b>		
51		Axle Bridge		1
52		Socket Head Cap Screw	M8-1.25x20	3
53		Wheel Axle		1
54		Washer	M20	6
55		External Snap Ring	For OD 20mm	6
56		Never-Flat Wheel		2
57		Hex Cap Nut	M20	2

## Parts List, Cont.

<b>Lift Mechanism Kit</b>				
<b>No.</b>	<b>Service Code</b>	<b>Description</b>	<b>Specification</b>	<b>Qty</b>
	<b>PGPLMK</b>	<b>PGP Lift Mechanism Kit</b>		
26		Chain	#60, 3/4" Pitch, 84 Links	1
30		Pawl Clutch		1
31		Pawl Clutch Pin		1
32		Pawl Clutch Housing		1
36		Sliding Bar		1

<b>Chain Lock Shaft Hardware Kit</b>				
<b>No.</b>	<b>Service Code</b>	<b>Description</b>	<b>Specification</b>	<b>Qty</b>
	<b>PGPCLSHK</b>	<b>PGP Chain Lock Shaft Hardware Kit</b>		
35		Chain Lock Shaft		1
49		Nord-Lock Washer Pair	M12	1
49A		Slot-Lock Washer		1
50		Flanged Hex Nut	M12-1.75	1

<b>Jaw Bumper Kit</b>				
<b>No.</b>	<b>Service Code</b>	<b>Description</b>	<b>Specification</b>	<b>Qty</b>
	<b>PGPJBK</b>	<b>PGP Jaw Bumper Kit</b>		
45		Socket Head Cap Screw	M6-1.0x25	4
46		Jaw Bumper		2

## Parts List, Cont.

Hardware Specification Information				
No.	Service Code	Description	Specification	Qty
3		Internal Snap Ring	For ID 42mm	1
4		Ball Bearing	6004-2RS	1
5		External Snap Ring	For OD 20mm	1
7		Socket Head Cap Screw	M6-1.0x30	4
8		Socket Head Cap Screw	M8-1.25x35	8
11		Internal Snap Ring	For ID 110mm	1
12		Ball Bearing	6014-2RS	1
13		External Snap Ring	For OD 70mm	1
16		Button Head Cap Screw	M8-1.25x15	4
18		Button Head Cap Screw	M8-1.25x15	2
22		Socket Head Cap Screw	M10-1.5x20	2
25		Socket Head Cap Screw	M8-1.25x40	4
28		Button Head Cap Screw	M5-0.75x6	6
37		Spacer	Φ33xΦ18.5x10	2
39		Washer	M18	2
40		Nylon-Insert Lock Nut	M18-1.5	2
45		Socket Head Cap Screw	M6-1.0x25	4
48		Button Head Cap Screw	M8-1.25x15	2
49		Nord-Lock Washer Pair	M12	1
50		Flanged Hex Nut	M12-1.75	1
52		Socket Head Cap Screw	M8-1.25x20	3
54		Washer	M20	6
55		External Snap Ring	For OD 20mm	6
57		Hex Cap Nut	M20	2
59		Socket Head Cap Screw	M8-1.25x15	2
62		Washer	M6	2
63		Split Lock Washer	M6	2
64		Socket Head Cap Screw	M6-1.0x15	2